

Aluminum Damper

A38/A39

5" Deep • 4" Airfoil Blade • Control Damper

STANDARD CONSTRUCTION

- FRAME:** 5" x .081" extruded aluminum, hat shaped
- BLADES:** 4" x .081" extruded aluminum, single unit airfoil design, with the pin-lock an integral section within the blade core
- AXLES:** ½" dia. extruded aluminum, pin-lock design interlocking into blade section
- BEARINGS:** Celcon
- LINKAGE:** Aluminum crank-arm permanently locked to have the blade shaft by 2 stainless steel fasteners; Crank-arm contains a ½" dia. cadmium plated and chromate treated machined steel trunnion riding in a celcon bearing; A plated steel ¼-20 set screw with locking patch, ties the pivot to the 5/16" dia. aluminum linkage rod; The linkage of each damper is individually adjusted
- SEALS:** Extruded silicone rubber seal
- FINISH:** Mill
- ACTUATOR:** 6" extended shaft; dampers more than one panel wide or high and operated with one actuator must be jackshafed; Factory supplied actuators are shipped loose to be mounted external as standard

OPTIONS

- Hand Quadrants
- 120V, 24V, or Pneumatic Actuators
- Jackshafing
- Auxillary Switch
- Explosion Proof Housing

NOTES

1. "A" width and "B" height are opening dimensions. Dampers are provided approximately ¼" undersize.
2. Dampers with multiple panels in both width and height may require structural support. It is recommended that large openings be designed with structural members so that dampers will span either width or height with a single panel. L&D does not supply structural support with standard dampers.
3. Not recommended for blades installed vertically.
4. Approximate damper weight is 5.5 lbs./sq.ft.

DAMPER SIZE

Panels	Minimum Panel	Maximum Panel
A38	12"W x 12"H	60"W x 72"H
A39	12"W x 14½"H	60"W x 72"H

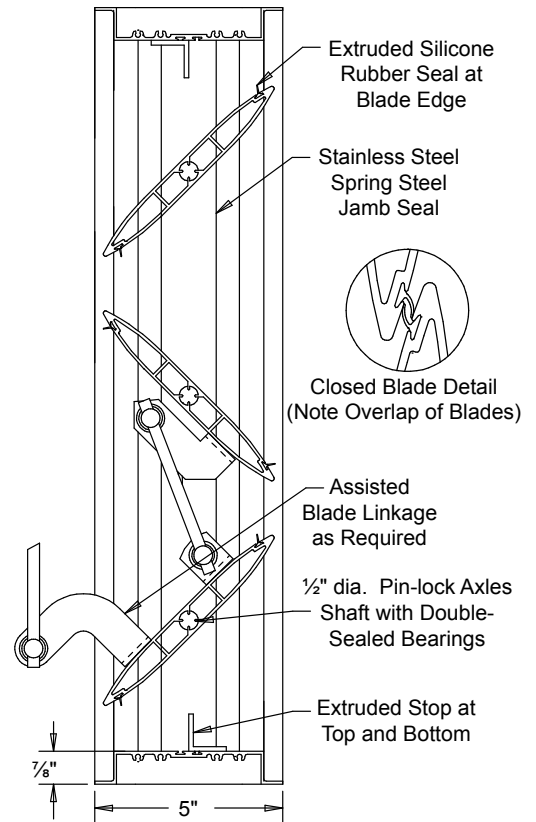
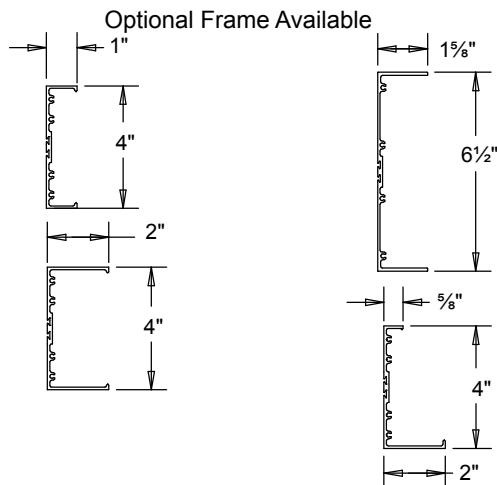

A39 (Opposed Blade)

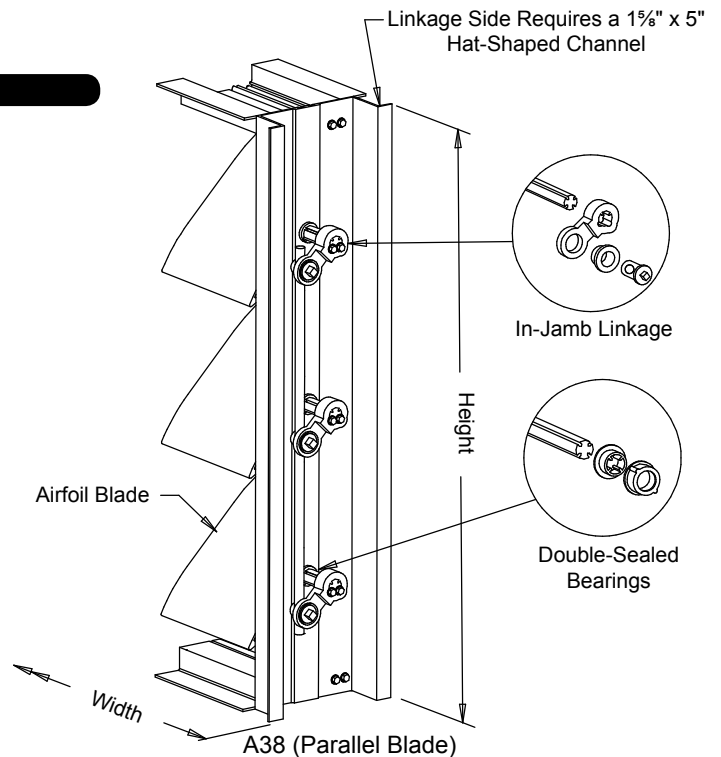

Louvers & Dampers
A Mccook Company

SD-A38-A39-13.02

450 Riverside Dr • Wyalusing PA, 18853 • Phone 570-746-1888 • Fax 570-746-9286

February 2013

Pressure Drop:

Pressure Drop Ratings are based on AMCA Standard 500 using test set-up Fig. 5.3 for damper installed with duct upstream and downstream. Static pressures are corrected to .075 lb./cu.ft. air density.

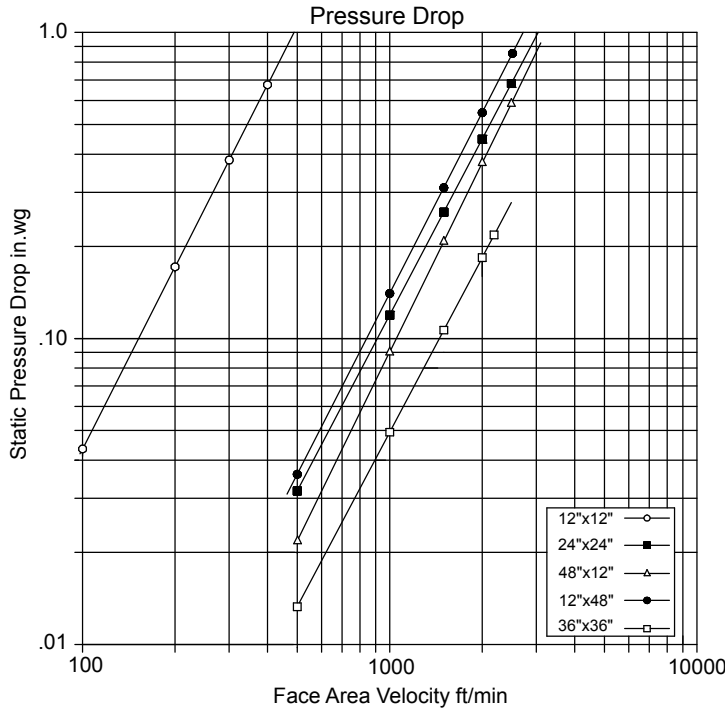

12"W x 12"H		24"W x 24"H	
Face Area Velocity ft/min	Pressure Drop in.wg	Face Area Velocity ft/min	Pressure Drop in.wg
100	0.04	500	0.03
200	0.16	1000	0.12
300	0.38	1500	0.25
400	0.69	2000	0.45
500	1.00	2500	0.68

12"W x 48"H		48"W x 12"H	
Face Area Velocity ft/min	Pressure Drop in.wg	Face Area Velocity ft/min	Pressure Drop in.wg
500	0.04	500	.02
1000	0.14	1000	.09
1500	0.31	1500	.20
2000	0.56	2000	.38
2500	0.85	2500	.58

36"W x 36"H	
Face Area Velocity ft/min	Pressure Drop in.wg
500	0.01
1000	0.05
1500	0.10
2000	0.18
2500	0.21

Leakage

Air Leakage requirements meet international energy conservation code (IECC) by leaking less than 3 cfm/sq.ft. at 1 in.wg and is AMCA licensed as a Class 1A Damper

Damper Size	1 in.wg Class	4 in.wg Class
12"W x 12"H	1A	1
24"W x 24"H	1A	1
36"W x 36"H	1A	1
12"W x 48"H	1A	1
48"W x 12"H	1A	1
60"W x 36"H	1A	1

Leakage Ratings are based on AMCA Standard 500 using test set-up Fig. 5.5 at an operation temperature range between 50°F & 104°F. Data is based on a seating torque of 40 lb/in for dampers less than 4 sq.ft in size. Dampers above 4 sq.ft., 5 lb/in/sq.ft is applied to hold the damper in the closed position.

Damper Air Leakage Classification

		Leakage cfm/ft ²	
		Required Rating	
Class	Pressure	1 in.wg	4 in.wg
		1A	3
1		4	8
2		10	20
3		40	80

5" Deep • 4" Airfoil Blade • Control Damper

Linear Air Flow Characteristics

L&D has tested a variety of airfoil blade widths 4", 5", and 6" in various arrangements from all parallel, all opposed, and combinations of parallel and opposed blades in a common frame for a single damper installed in a duct.

Test units were installed in ductwork with duct upstream and downstream per AMCA test set-up Fig. 5.3. Using most common approach velocities and fan static.

The results of the tests show that fan static pressure does have an effect on the linear air flow characteristics of a damper. Graphs below will identify the simulated system conditions used for the single damper in duct system application

Curves shown in the graphs below show that model A39 all opposed "as standardly built" is a very effective control damper for use in a variety of velocities and pressures.

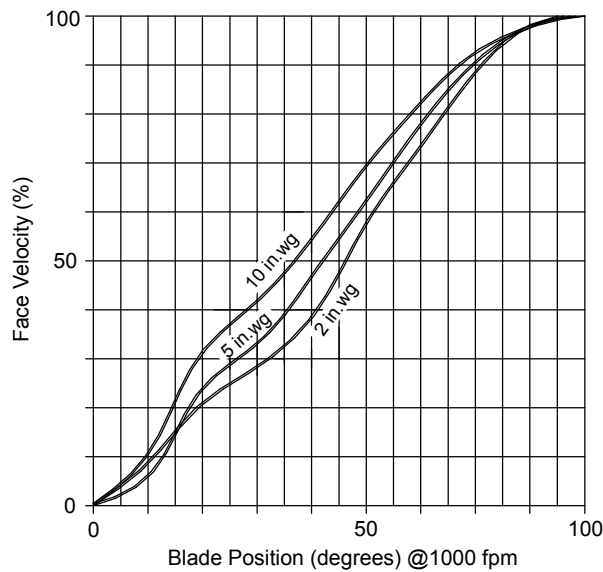
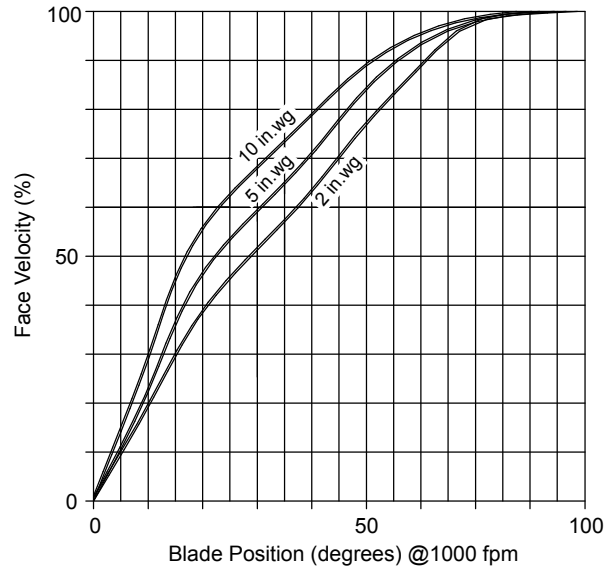

This page intentionally left blank.